

DANPAL® EVERBRIGHT

The Strong Unique
Building Solution



FACADE



ROOFING





Brooke Street Pier, Hobart
Architect: Circa Morris Nunn





McAuley Community School
Architect: Swanbury Penglase

**EVERBRIGHT IS A STRONG,
SELF-SUPPORTING BUILDING
SOLUTION THAT IS EASY TO
INSTALL.**

**CLEAN
LOOKING
OFFERING
LARGE
SPANS**

It can free span up to 12 metres in curved applications and 4.38 metres in skillion applications with no intermediate framing.

The 74mm deep panels provide soft naturally diffused light, while still offering a degree of transparency. The system offers superior fire performance and excellent thermal insulation, as well as full UV protection.

Everbright can be easily assembled as a dry-glazed system, greatly reducing on-site construction times.

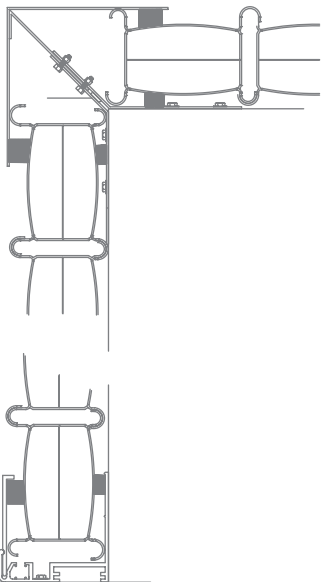

Facade corner and edge details

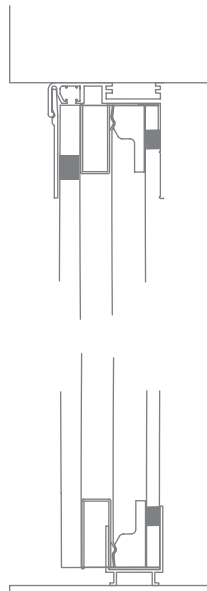

Facade head and sill details

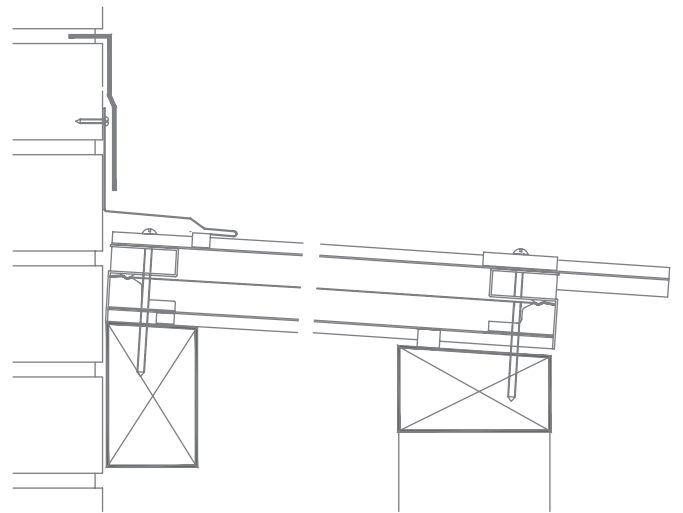

Roof wall and fascia details

THE STRONGEST TRANSLUCENT SYSTEM IN THE WORLD!

SYSTEM BENEFITS

- Excellent Fire Performance
- High Insulation
- Easy Installation
- Rigid and Safe
- Waterproof
- Straight and Curved
- Roofs and Walls
- Large Spans
- 74mm Thickness

Byford Secondary College, Western Australia
Architect: Donaldson & Warn

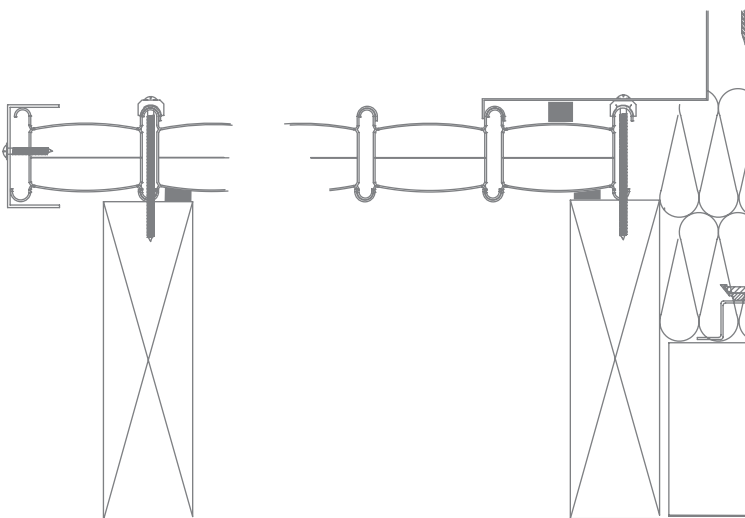

Roof edge details



National Lifestyle Village Multi Sports Hall



Magdalene Catholic College:
Architect: Alleanza



Australian Centre of Excellence Eureka Stockade Victoria
Architect: William Boag Allen Architects

OPTICAL AND SOLAR PROPERTIES

	LT%	ST%	SR%	SHGC
Clear	75*	75	20	0.76
Blue	54*	64	22	0.67
Opal	62*	57	25	0.61
Ice White	32*	35	34	0.42

* 10% less when using 1 cell of Nanogel. 20% less when using 2 cells of Nanogel

SPAN TABLE

Load (kPa)	Maximum span for downward load (m)	Maximum span for uplift load (m)
0.5	4.75	5.49
0.75	4.38	4.81
1	4.11	4.41
1.25	3.91	4.14
1.5	3.76	3.94
1.75	3.63	3.3
2	3.51	3.51
2.5	3.33	3.33
3	3.19	3.19

TECHNICAL FEATURES

U-value (W/m ² °K)	Standard	with Polycool inserts	1 cell of Nanogel	2 cells of Nanogel
	1.8	1.48	0.84	0.62

Fire classification	ISO 9705 Group 2 result
Minimum slope	3 degrees
Manufactured according to certification	ISO 9001 ISO 14001
Impact resistance	AS1562-3

COLOUR YOUR ATMOSPHERE WITH THE DANPAL® PALETTE



ABOUT THE COMPANY

Innovative light architecture systems for building envelopes

Danpal® are creators of exceptional light-transmitting architectural systems for building envelopes, providing optimal solar and thermal comfort.

For over 30 years, our innovative systems have helped architects to transform light (both natural and artificial) into a powerful and versatile tool, for architectural creations that are internally and externally radiant.

An industry visionary, Danpal® are originators of the Danpalon® translucent panel standing seam system - a light architecture solution used around the world in commercial, education, transport, health, sports and high-tech projects.

Today, the company offers complete systems - providing total solutions for the building envelope. Danpal® designs, manufactures and distributes an unmatched range of daylighting systems for all types of building requirements - from facades, cladding, roofs, skylights, shading, to interior and outdoor applications.

Danpal® systems are built around innovative technologies, deep architectural know-how and the ever evolving needs of our clients. Operating in five continents, Danpal® inspires architectural creativity with its rainbow of light architecture solutions.

Danpal® Everbright is an integral part of Danpal's range of systems - giving you a complete solution



FACADES



CLADDING



ROOFING



SKYLIGHTS



SHADING



INTERIOR

www.danpal.com.au

